

Ταχυρολόα

MTZ FU 05-7-90 KU

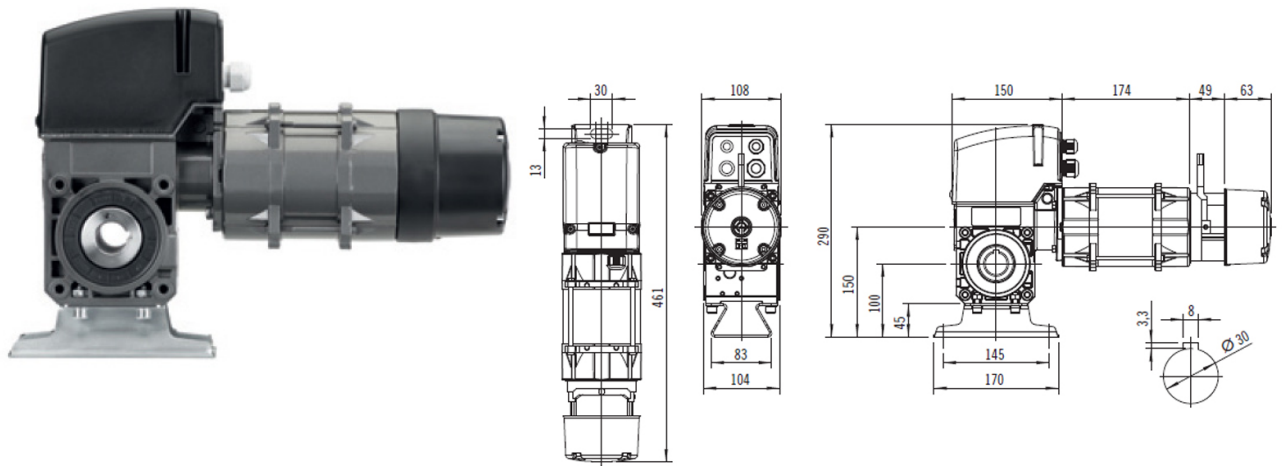

MTZ FU 05-7-90 KU - Specifications

driving torque (50 Hz / 87 Hz)	70/49 Nm
maximum safety catch torque	258 Nm
driving motor speed (50 Hz / 87 Hz)	90/156 min⁻¹

motor output	0,9 kW
operating voltage	400V / 3~
mains frequency	50 Hz
control voltage	24 V
motor current rating	2,9 A
* max. cycles per hour	30
supply cable, on site	5x1,5 mm²
fuse protection, on site	10,0 A
protection grade	IP 54

temperature range	-20 / +60 °C
continuous sound pressure level	< 70 dB(A)
individual weight	19 kg
maximum output revolutions	20
Ø sleeve shaft	25 / 25,4 / 30 mm

Works with:



HEAVY 1

MTZ FU 20-10-45 KU

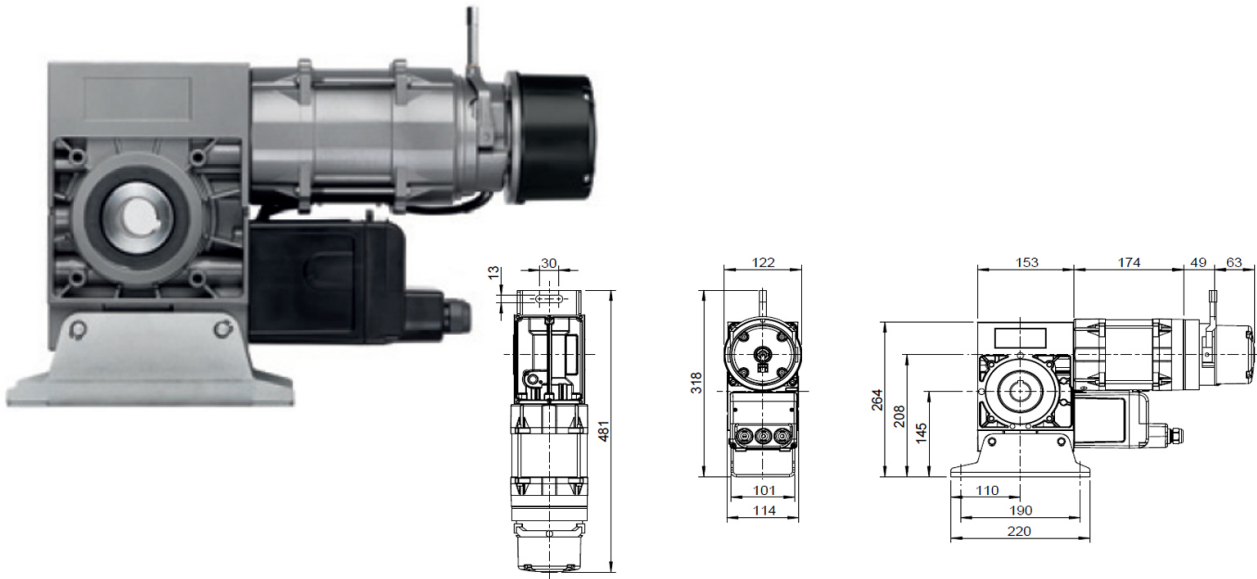

MTZ FU 20-10-45 KU - Specifications

motor output	750 Nm
motor current	10 min⁻¹
motor duty cycle	1,5 kW
operating voltage	400V / 3~ 50 Hz

control voltage	24 V
driving torque	7,2 A
driving motor speed	6
protection grade	IP 54

Works with:



HEAVY 1

GAPOSA LP6090TMM

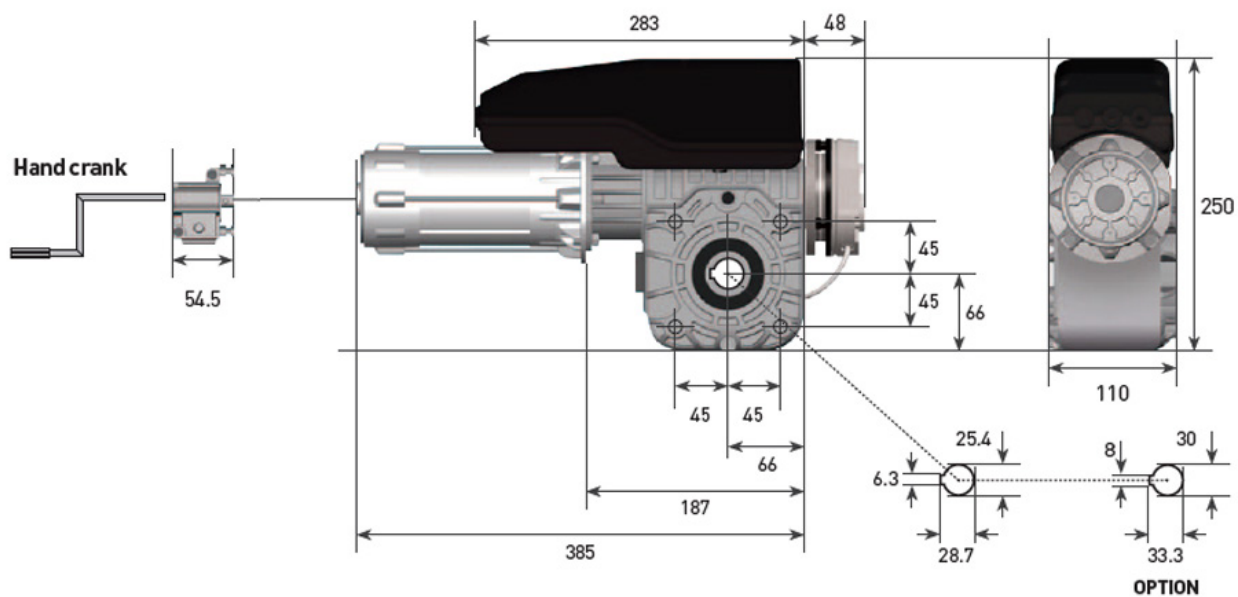

GAPOSA LP6090TMM - Specifications

Power Supply	400 Vac
Frequency	50 Hz
Torque	60 Nm
Output Speed	90 min⁻¹

Power	0,95 kW
Absorbition	2.5 A
Max cycles per hour	45
Limit Switch max turns	18

Temperature	-5°C/40°C
Protection Rate	IP 54

Works with:

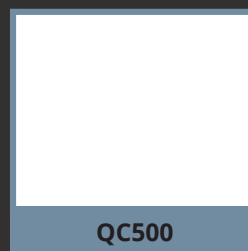
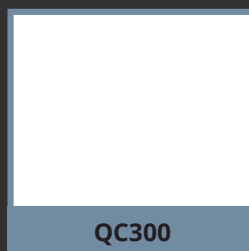
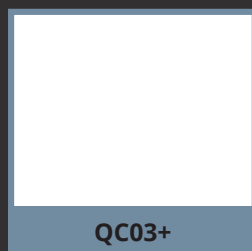
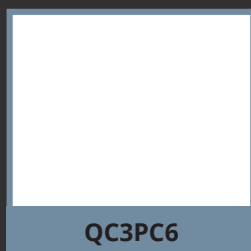

GAPOSA LP12045TMM

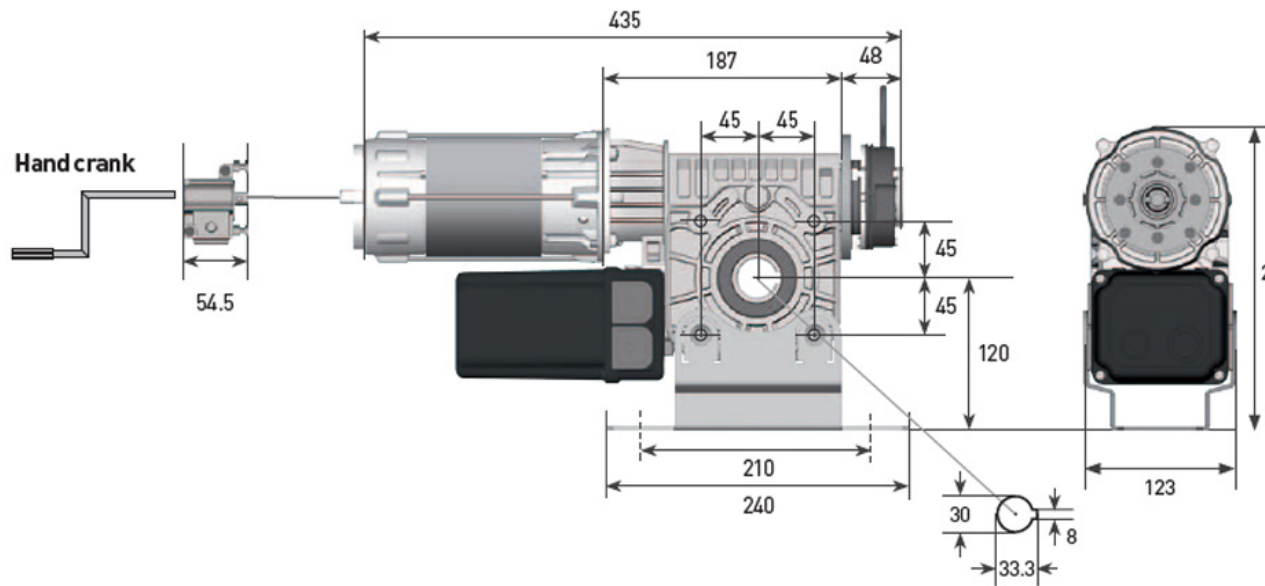

GAPOSA LP12045TMM - Specifications

Power Supply	400 Vac
Frequency	50 Hz
Torque	120 Nm
Output Speed	45 min⁻¹

Power	0,7 kW
Absorbition	1.8 A
Max cycles per hour	25
Limit Switch max turns	18

Temperature	-5°C/40°C
Protection Rate	IP 54

Works with:

